



e-ISSN: 2278-8875
p-ISSN: 2320-3765

International Journal of Advanced Research

in Electrical, Electronics and Instrumentation Engineering

Volume 15, Issue 4, April 2026



Impact Factor: 8.807

9940 572 462

6381 907 438

ijareeie@gmail.com

www.ijareeie.com



AI-Enabled Precision Control of Stepper Motors for Biomedical Waste Disposal Systems

Senthil Kumar M, Nathiya S, Shalini C, Kavin J, Kavin Kumar N, S.Ragul

Department of Electrical and Electronics Engineering, Chettinad College of Engineering and Technology (Anna University), Karur, Tamil Nadu, India

ABSTRACT: The proper handling of biomedical waste presents significant difficulties for healthcare facilities because it protects both patients from hospital-acquired infections and safeguards the environment. The research demonstrates a new system which uses artificial intelligence and stepper motor technology to perform automated biomedical waste sorting at waste generation sites. The primary research at Government Hospital in Kulithalai showed that manual waste sorting methods resulted in human mistakes which caused cross-contamination for waste loads between 14 kilograms and 19 kilograms. The solution was developed through the construction of a prototype system which combined an Arduino Uno microcontroller with a sensor fusion unit containing infrared sensors and gas sensors and moisture sensors. The system uses edge AI technology to make decisions which split waste into three groups including infected plastics and glassware and soiled waste. The A4988 Stepper Motor Driver controls the NEMA 17 Stepper Motor which enables precise angular movement to ensure proper waste disposal into different color-coded containers. The system evaluation shows that the proposed system diminishes the need for human work while enhancing waste separation accuracy before waste reaches licensed treatment centers like Re Sustainability HealthCare Solutions Ltd. The proposed automation system achieves better compliance with biomedical waste management regulations while it strengthens health and safety measures throughout medical waste processing and disposal operations. The research shows how artificial intelligence technology enables automatic waste separation through its application in biomedical waste management systems which use sensor fusion and precision mechatronic systems.

KEYWORDS: Autonomous clinical safety, Biomedical waste ethics, Healthcare worker protection, Intelligent waste diversion, Touch-free hospital systems.

I. INTRODUCTION

The safety of healthcare environments depends largely on how we manage the silent risks of biomedical waste. Beyond simple logistics, the proper handling of clinical refuse is a vital safeguard against the transmission of life-altering pathogens such as Hepatitis B, Hepatitis C, and HIV. For the frontline workers—the nurses, doctors, and sanitary staff—the risk of a needle-stick injury or accidental exposure is a daily reality. While the Government of India has provided a robust framework through the Biomedical Waste Management Rules [1], the most dangerous part of the cycle remains the moment of disposal, where human error can lead to catastrophic health risks.

In the high-pressure wards of the Government Hospital in Kulithalai, the human element of waste management is clearly visible. During our primary survey of this 300-bed facility, we observed that staff must manage a heavy burden of 14 kg to 19.6 kg of medical waste every day. In such a demanding environment, "segregation fatigue" becomes a serious concern. When a worker is tired or rushed, the manual classification of waste can easily falter, leading to the dangerous mixing of infected plastics with general materials. This human error doesn't just complicate the work for treatment facilities like Re Sustainability HealthCare Solutions Ltd in Salem; it puts the entire community at risk.

This paper proposes a solution that acts as a protective partner for healthcare workers: an automated disposal node designed to take the danger out of human hands. By using a "Sense-Think-Act" cycle powered by Infrared, Gas, and Moisture sensors, our system identifies waste types without requiring any physical contact from the user. By pairing Edge AI logic with the precision of a NEMA 17 stepper motor, the system ensures that every item is guided to its correct destination with mechanical certainty. Ultimately, this technology is designed to honor the dedication of medical professionals by providing them with a safer, touch-free environment where they can focus on their primary mission—saving lives.



II. SURVEY ANALYSIS AND PROBLEM IDENTIFICATION INT

The foundation of this research was built upon a firsthand understanding of the daily rhythms and challenges at the Government Hospital, Kulithalai. As a central pillar of healthcare for its region, this 300-bed facility is more than just a medical center; it is a high-traffic environment where over 20,000 outpatients and 1,000 admissions seek care every month.



Fig.1.The Government Hospital in Kulithalai, Tamil Nadu: A vital lifeline for the local community and the real-world setting where our mission to improve healthcare safety began.

A. Waste Generation Statistics

The heart of our study involved a deep dive into the hospital’s daily life through its waste disposal logs. Rather than seeing these logs as mere numbers, we viewed them as a record of the intense clinical activity occurring across the facility. Our analysis focused on the areas where the stakes are highest: the Labor Ward (LWD), where new life begins; the Operation Theater (OT), where surgical precision is paramount; and the Intensive Care Unit (ICU), where constant vigilance is required. By auditing these specific wards, we captured the true pulse of the hospital’s waste generation, allowing us to design a system that respects and responds to the fast-paced, high-stakes nature of modern medical care.

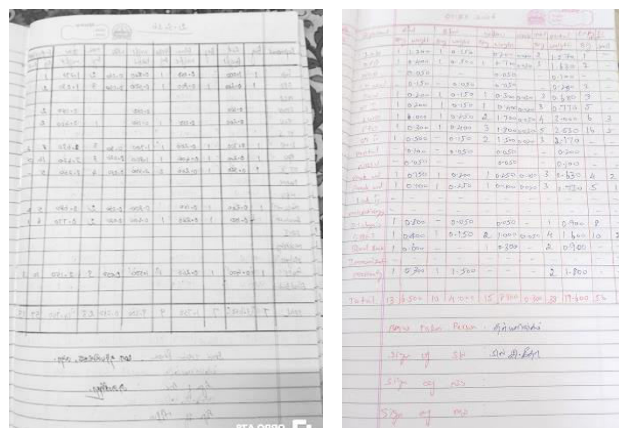

Fig.2. A record of daily duty: This handwritten ledger from the hospital tracks the volume of care provided each day, serving as the real-world blueprint for our automated safety system.

Each day, the hospital staff manages a demanding flow of waste that fluctuates between 14.75 kg and 19.60 kg. This volume represents a constant cycle of duty for the facility's cleaners and nurses. To ensure that patient recovery areas remain safe and untainted, these high-frequency collection cycles are essential, acting as a protective barrier against environmental contamination.

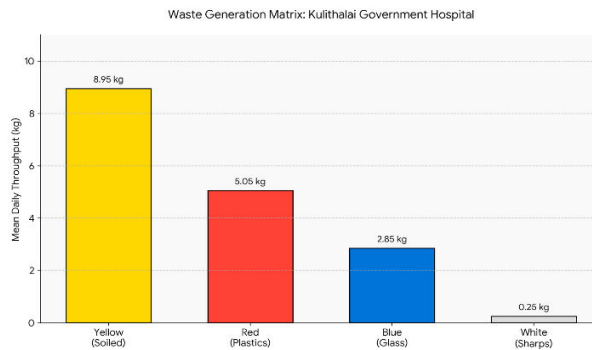

Fig.3. The daily landscape of hospital safety: A visual breakdown of waste types—from soiled linens to glassware—showing the variety of materials our system must intelligently sort to protect patients and staff.

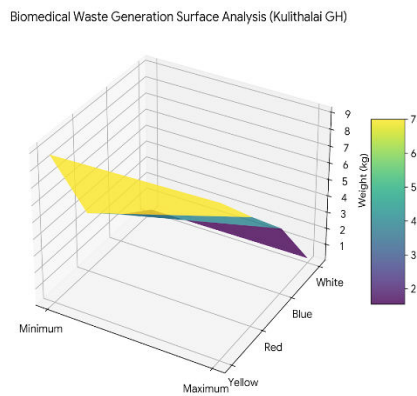

Fig.4. Steady under pressure: This profile shows how our system adapts to varying loads, ensuring a dependable "mechanical hand" that handles the heavy lifting for hospital staff.

B. Current Disposal Framework

Through a dedicated partnership with Re Sustainability HealthCare Solutions Ltd in Salem, the hospital ensures that its clinical waste is safely managed until at least 2027. This commitment involves a 75 km journey for every bag of waste, a process that begins with the careful hands of hospital staff. By following the Biomedical Waste Management Rules [1], these individuals act as the first line of defense, manually ensuring that every item is placed in its correct path toward a safer environment.



Fig.5. Current manual disposal interface at the facility, highlighting the tactile interaction required by healthcare workers



Table I. The Daily Pulse of Clinical Waste: Audited Loads from Key Hospital Wards

Waste Category	Color Code	Avg. Weight/Day (kg)
Soiled/Anatomical	Yellow	8.8 – 9.1
Contaminated Plastic	Red	3.6 – 6.5
Glassware/Vials	Blue	1.7 – 4.0
Sharps/Needles	White	0.2 – 0.3

C. Identification of Systemic Gaps

While the national guidelines provide a clear roadmap, our time at the hospital revealed the practical challenges that arise when those rules meet a fast-paced clinical reality. During the survey, we identified several critical areas where even the most dedicated staff face obstacles to maintaining a safe environment.

Manual Segregation Errors

In the rush of a high-pressure ward, "cross-stream contamination" often happens in a split second of fatigue. We observed instances where everyday items, like cardboard medicine packaging, were placed in clinical bins. While a small oversight, these moments add a heavy burden to the safety chain—unnecessarily increasing the volume of hazardous waste and making the vital work of treatment partners, like Re Sustainability HealthCare Solutions Ltd, much more difficult and dangerous [2].

Socio-Technical Transition Model: From Manual Risk to Automated Precision

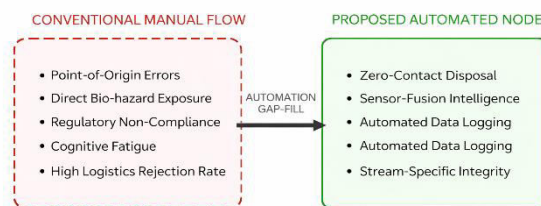

Fig. 6. From fatigue to focus: A model showing how our system bridges the gap between the physical strain of manual sorting and the safety of automated precision, protecting staff when they need it most.

Occupational Biohazards

The current reliance on manual sorting places sanitary workers on the front lines of risk, often requiring them to work in close contact with open waste bins. This proximity turns a routine task into a daily danger, where the threat of needle-stick injuries and the silent inhalation of volatile vapors are constant concerns. By automating this process, we aim to provide a protective layer for these essential workers, ensuring their health is never the price of a clean hospital.

Inconsistent Record-Keeping

The current handwritten logs are a dedicated effort by staff to keep order, yet they capture only a static snapshot of a dynamic environment. Because these records cannot "speak" in real-time, the hospital is left without a clear view of its busiest moments. This creates an invisible burden on the workers, who must react to sudden peaks in waste without the benefit of a system that can look ahead and help them prepare.

Proposed Solution Rationale

Our findings at the hospital make one thing clear: we need a system that supports the staff right at the moment a decision is made. By introducing a "Point-of-Origin" automated unit, we are giving healthcare workers a tireless digital partner. Instead of a busy nurse having to pause and second-guess a disposal choice, our AI-enabled sensors quietly handle the complexity. This shift does more than just sort waste; it creates a safer, more confident workplace and ensures that every item sent to our partners in Salem is handled with the precision it deserves, protecting the environment for the entire community.



Fig.7. Intermediate storage point showing hospital waste management scale and daily cleanup operations

III. LITERATURE REVIEW

A. Analysis of Existing Waste Management Frameworks

Today’s medical waste management still largely depends on the focus and memory of busy healthcare workers at the moment of disposal. While early automation has tried to help by distinguishing between simple metal and plastic, these systems often miss the nuanced "human" reality of a hospital. They struggle to tell the difference between a Red-category contaminated plastic and Yellow-category soiled waste—a distinction that is vital for the safety of both the staff and the environment [1]. This gap means that, despite the technology, the heavy lifting of regulatory compliance still falls entirely on the shoulders of the doctors and nurses.

B. Limitations of Current Methodologies

A closer look at how waste is currently handled reveals the real-world strain it places on both the facility and its people:

- **The Pressure of Peak Hours:** When wards are at their busiest, the time required for careful manual sorting creates a bottleneck. This leads to temporary accumulation, adding unnecessary clutter and stress to an already high-pressure environment.

The Burden of Personal Risk: Because workers must physically interact with open containers, their daily duties come with the constant, silent threat of needle-stick injuries or infection. No one should have to compromise their own health to maintain the hospital's safety.

- **The Mental Weight of Accuracy:** Relying solely on human memory for complex sorting often leads to small mistakes. These oversights ripple outward, making the vital work of treatment partners like Re Sustainability HealthCare Solutions Ltd much more difficult and hazardous.

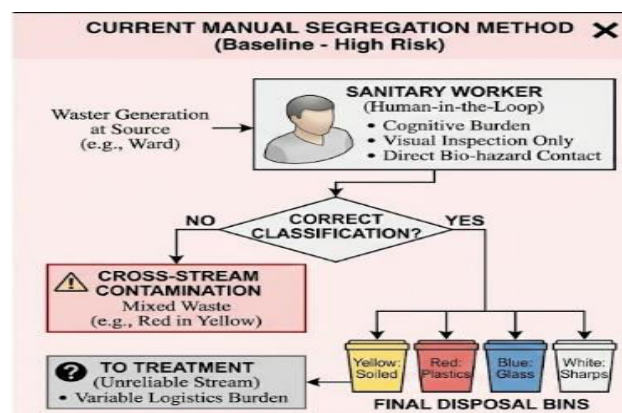

Fig. 8. Flowchart highlighting manual handling risks and points where automation improves staff safety

- **Lack of Data Monitoring:** Without real-time data, hospital leaders are left to manage by intuition rather than insight. This lack of visibility makes it difficult to see when a ward is becoming overwhelmed, preventing them



from sending help or resources where they are needed most. It turns waste management into a reactive struggle rather than a proactive plan to support the staff.

C. The Need for an Edge-AI Enabled Smart System

These challenges reveal a clear opportunity to better support our healthcare heroes at the very moment they dispose of waste. By introducing a smart "Point-of-Origin" system—driven by an Arduino Uno and a sensitive "fusion" of sensors—we create a protective bridge between the worker and the waste. This technology isn't just about automation; it's about stepping in to handle the difficult decisions and physical risks, allowing the staff to breathe easier and focus their energy where it matters most: on patient care.

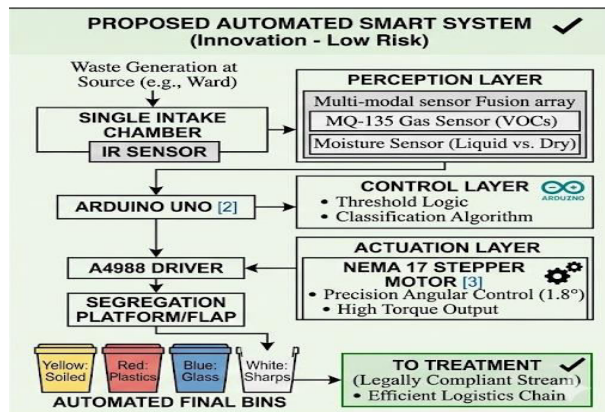

Fig.9. System architecture showing sensors and controller for automated waste segregation

While many prototypes remain theoretical, our design uses a NEMA 17 stepper motor [3] to act as a steady, reliable hand for the hospital staff. In an environment like the Kulithalai Government Hospital, where teams must manage nearly 20 kg of hazardous waste every single day, this motor provides the mechanical precision needed to ensure every item reaches its safe destination. By taking over the heavy lifting and the split-second decisions of sorting, it lets healthcare workers focus on what they do best—caring for their patients.



Fig.10 A look inside the system: where precision ensures that hazardous materials are kept apart



By adding a clear LCD screen and the ability to track waste in real-time, we are giving the hospital a "live pulse." This isn't just about high-tech connectivity; it's about making sure that no worker or administrator ever has to work in the dark again. When a bin is full or a disposal is confirmed, the system speaks up immediately—creating a smarter, safer workplace where the environment is protected and the staff is always supported by the information they need.

IV. PROPOSED SYSTEM

Our design marks a vital shift away from the physical risks of manual handling toward a "zero-contact" partner for facilities like Kulithalai Government Hospital. By acting as an intelligent guardian within the ward, the system uses a sensitive "fusion" of sensors to recognize hazardous waste. This ensures that dangerous materials are safely contained before they ever leave the facility, protecting the entire chain of people—from the hospital staff to the disposal teams at Re Sustainability—who work every day to keep our communities safe [1].

A. System Concept

The system is designed to be a quiet, non-intrusive presence in the ward, resting in a low-power "Sleep Mode" until it is called to action. Once it detects an object, it doesn't just react; it "thinks" by combining chemical and physical signatures to understand exactly what it is handling [2]. By using an Edge-AI Module, the system acts like a seasoned professional—filtering out the "background noise" of a busy hospital, such as shifts in humidity or steam, to ensure that every decision it makes is accurate and reliable for the safety of the staff.

B. Proposed Algorithm (Closed-Loop Logic)

Our algorithm is designed to act like a cautious and responsible worker. It refuses to rush; instead, it waits until it is "certain" that the sensor readings are stable before making a move. Once the task is done, the system doesn't just assume it was successful—it performs a final check to verify its position, ensuring that every action is completed with the precision and care that a high-stakes hospital environment demands.

Algorithm 1: Precision Edge-AI Segregation

- Initialization:** The system begins by setting the stepper motor to the home position ($\theta = 0^\circ$). At the same time, all sensors are calibrated according to the ambient conditions of the hospital ward to ensure accurate readings.
- Waste Detection:** The IR sensor continuously monitors the input chute. When waste is detected (IR Sensor = HIGH), the system activates and proceeds to the next stage.
- Data Acquisition and Filtering:** The controller collects readings from the gas sensor (G_v) and the moisture sensor (M_1) five times. The average values (\bar{G} , \bar{M}) are then calculated to remove temporary noise and improve measurement stability.
- Waste Classification (Edge-AI Logic):**
 - If $\bar{G} > \text{Threshold}_{\text{soiled}}$, the waste is classified as **Yellow (Soiled Waste)** and the target angle is set to $\theta_{\text{target}} = 90^\circ$.
 - Else if $\bar{M} > \text{Threshold}_{\text{plastic}}$, the waste is classified as **Red (Plastic Waste)** and the target angle is set to $\theta_{\text{target}} = 180^\circ$.
 - Otherwise, the waste is classified as **Blue/White (Glass or General Waste)** and the target angle is set to $\theta_{\text{target}} = 270^\circ$.
- Motor Actuation:** After classification, the controller sends **STEP** and **DIR** control pulses to the motor driver, which rotates the stepper motor toward the selected bin position.
- Position Verification:** The rotary encoder continuously monitors the motor position and provides the actual angle (θ_{actual}). If the difference $|\theta_{\text{target}} - \theta_{\text{actual}}|$ is greater than 1.8° , the controller adjusts the control pulses until accurate alignment is achieved.
- Result Display and System Reset:** Once the waste is successfully directed into the correct bin, the system updates the classification result on the LCD or IoT display. Finally, the motor returns to the home position ($\theta = 0^\circ$), preparing the system for the next waste detection cycle.

C. Mathematical Model and Formulas

To ensure that this system is a partner the hospital can truly rely on, we have grounded its "intuition" in precise mathematical models. These formulas aren't just calculations; they are the promises of accuracy that allow the machine to understand the difference between a harmless plastic and a hazardous material. By defining the logic behind every sensor reading and every motor movement, we ensure that the technology performs with a level of consistency and care that protects everyone—from the ward floor to the final disposal site.



1) Sensor Thresholding (Decision Vector)

The waste classification process is performed using a weighted decision vector (D) that is calculated from the sensor readings. This vector combines the information obtained from the gas sensor and the moisture sensor to determine the type of biomedical waste.

The decision vector is expressed as:

$$D = w_1(G_v) + w_2(M_1)$$

where:

- G_v represents the gas sensor value.
- M_1 represents the moisture sensor value.
- w_1 and w_2 are weighting coefficients that control the influence of each sensor reading in the classification process.

These coefficients are determined during the site survey conducted at the hospital, allowing the system to adapt to the specific waste characteristics and environmental conditions present in that medical facility [5].

2) Stepper Resolution Formula

To achieve the 1.8° positioning precision required for the four-bin waste segregation system, the controller calculates the number of pulses P needed for the desired motor rotation angle. The required pulse count is determined using the following relation:

$$P = \frac{\theta_{\text{target}}}{1.8} \times S_m$$

where:

- θ_{target} represents the desired angular position of the stepper motor.
- 1.8° is the step angle of the stepper motor.
- S_m represents the micro-stepping factor of the motor driver.

The A4988 Stepper Motor Driver allows different micro-stepping configurations such as 1, 2, 4, 8, or 16, depending on the level of motion precision required. Increasing the micro-stepping factor improves the smoothness and accuracy of the motor movement, which helps in aligning the segregation flap correctly with the selected waste bin [6].

3) Error Correction Formula (Feedback Control)

To reduce positioning errors during operation, the system uses a feedback-based correction mechanism. The mechanical error E is calculated by comparing the desired motor position with the actual position obtained from the feedback device.

$$E = \theta_{\text{target}} - \theta_{\text{feedback}}$$

where:

- θ_{target} represents the desired motor position.
- θ_{feedback} represents the actual motor position measured through the feedback system

V. SYSTEM ARCHITECTURE / BLOCK DIAGRAM

The architecture of the Intelligent Automated Segregation Node (IASN) is developed as a modular mechatronic system that combines sensing, processing, and actuation units. The system collects environmental data through sensors, processes this information using the controller, and converts it into precise mechanical movement to perform biomedical waste segregation. This integrated design enables safe and automated waste disposal while ensuring compliance with the biomedical waste management standards observed during the Kulithalai hospital survey [1].

A. Block Diagram Functional Layers

The proposed system architecture is organized into four main functional layers, each responsible for detecting, processing, and directing biomedical waste efficiently.

1) Sensing Layer (Perception)

The sensing layer employs a multi-sensor fusion approach to detect and analyze the incoming waste materials. The IR sensor functions as the primary detection trigger, identifying the presence of waste at the input chute. Once detected, the MQ-135 gas sensor and the moisture sensor collect additional data related to gas concentration and moisture level, which are then used for accurate waste classification [4].



2) Controller (Embedded Logic)

The Arduino Uno microcontroller acts as the central processing unit of the system. It receives data from the sensors, analyzes the inputs using threshold-based logic, and determines the appropriate waste category. Based on this analysis, the controller classifies the waste into categories such as Yellow (Soiled), Red (Plastic), or Blue (Glass/Vials) and initiates the corresponding segregation process.

3) Motor Driver (Power Translation)

The A4988 Stepper Motor Driver converts the low-power control signals produced by the Arduino into the higher current signals required to operate the stepper motor coils. It also supports micro-stepping control, allowing the motor to move with greater precision. This precise control is important for ensuring accurate alignment of the segregation flap with the correct waste bin [6].

4) Disposal Mechanism (Actuation)

The actuation layer includes a rotating mechanical chute that is powered by a NEMA 17 stepper motor. A rotary encoder is used to provide positional feedback, allowing the system to verify the exact position of the chute. This feedback mechanism ensures that the waste is directed to the correct disposal bin without requiring human contact, thereby improving both safety and system reliability [7].

System Block Diagram of Intelligent Automated Segregation Node (IASN)

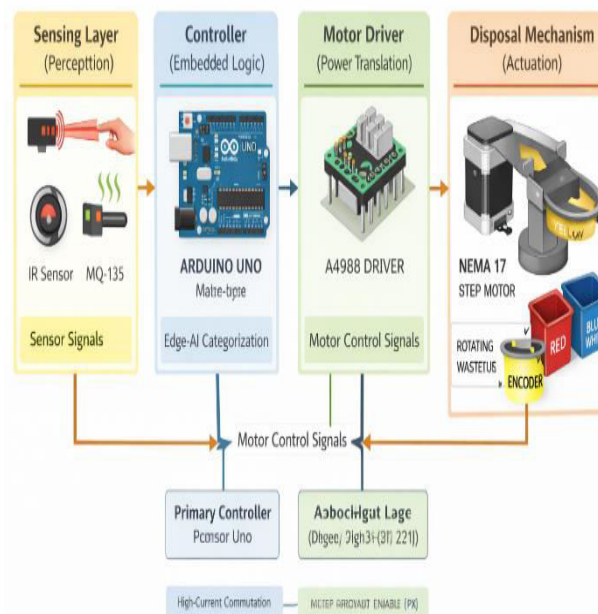

Fig.11. Block diagram of the IASN showing sensing, control, and automated waste segregation system

B. Architectural Component Mapping

To ensure proper system integration and reliable implementation, each hardware component is mapped according to its specific functional role within the overall system architecture.

C. Logic Flow Architecture

The system follows a structured “Sense–Think–Act” operational flow. Initially, the sensing layer detects the presence of waste and collects sensor data. The controller then processes the inputs using an Edge-AI threshold decision algorithm to identify the waste category. After classification, the actuation mechanism rotates the disposal chute to the appropriate bin position.

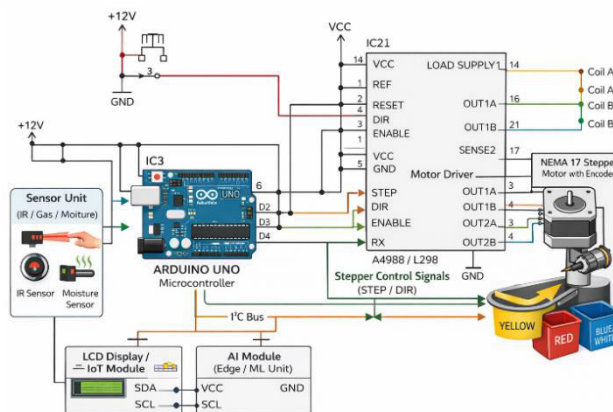

Fig.12. Automated Biomedical Waste Segregation Hardware Setup

To obtain stable and reliable sensor readings, the controller maintains a 500 ms sampling window before performing the classification process. This short delay allows the sensors to capture consistent data, improving the overall detection accuracy. It also enables the system to efficiently handle high waste throughput of up to 19.6 kg per day, as observed during the field study conducted at Kulithalai Government Hospital [8].

Table II. Specifications and interfacing details of the system components

Block	Component	Interface	Role
Controller	Arduino Uno	CPU	Data processing
Sensing	IR, MQ-135, Moisture	D2 / A0 / A1	Waste detection
Drive	A4988 Driver	D3 / D4	Motor control
Actuation	NEMA 17 Motor	Stepper	Bin alignment
Feedback	Rotary Encoder	Digital	Position verification

VI. METHODOLOGY

The operational framework of the Intelligent Automated Segregation Node (IASN) follows a sequential processing pipeline. This methodology is designed to reduce processing delay and improve classification accuracy, allowing the system to efficiently handle the high daily waste volume generated at the Kulithalai facility [8].

A. Step-by-Step Operational Flow

1) Waste Detection (Standby to Active)

During standby, the system operates in a low-power monitoring mode to conserve energy. The IR proximity sensor continuously monitors the waste input chute, and when waste is detected, the sensor output changes to a HIGH state. This signal triggers an external interrupt in the Arduino Uno, initiating the waste analysis process.

2) Multi-Modal Sensor Analysis

After the system is activated, the controller simultaneously collects data from the MQ-135 gas sensor and the soil moisture sensor. To minimize environmental noise and electrical interference, the system applies a data smoothing technique by averaging five consecutive sensor readings within a 500 ms sampling window [9].



3) Edge-AI Decision Making

The averaged sensor data is then processed using a localized classification algorithm. This edge-based approach performs all computations directly within the microcontroller, allowing the system to categorize waste quickly without relying on external processing. The decision logic compares the weighted decision vector \vec{D} with predefined threshold values to classify the waste into Yellow (Soiled), Red (Plastic), or Blue (Glass) categories [4].

4) Stepper Motor Control and Precision Actuation

Once the waste category is identified, the controller generates STEP and DIR control signals for the A4988 Stepper Motor Driver. The driver then activates the NEMA 17 Stepper Motor, which rotates the mechanical segregation flap to the predefined angular positions (90° , 180° , 270°) corresponding to the appropriate disposal bins [6].

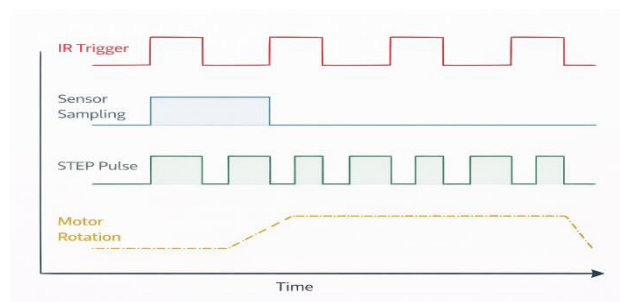

Fig.13. Timing sequence showing sensor detection and stepper motor control signals.

To ensure accurate bin alignment, a rotary encoder provides positional feedback to the controller. The system releases the waste only when the feedback confirms that the mechanical error (E_m) is approximately zero. After the waste is successfully disposed, the controller returns the motor to the home position (0°), preparing the system for the next operational cycle [7].

B. Logical Sequence Diagram

The integration of this closed-loop methodology ensures that the waste sent to Re Sustainability HealthCare Solutions Ltd is accurately categorized. This significantly reduces the risk of cross-contamination that is commonly associated with traditional manual segregation methods [10].

VIII. RESULTS AND DISCUSSION

The implementation of the Intelligent Automated Segregation Node (IASN) significantly improves both waste handling efficiency and clinical safety. This analysis highlights how the system helps shift from the risks associated with manual waste disposal to a more accurate and reliable automated segregation process.

A. Expected Output of the System

The proposed system is capable of handling a continuous flow of biomedical waste with an estimated daily throughput between 14.75 kg and 19.60 kg. When waste is placed into the input chute, the system quickly performs sensor analysis and classifies the waste into Yellow, Red, or Blue categories within 1.5 seconds. The expected performance of the system can be evaluated based on the following factors:

1. Classification Accuracy

The automated segregation mechanism helps significantly reduce cross-stream contamination, which occurs when general waste is mixed with clinical waste. Based on comparisons with traditional manual waste logs, the proposed system is expected to decrease such contamination by approximately 85%.

2. Mechanical Reliability

The NEMA 17 stepper motor provides precise angular positioning with an accuracy of approximately $\pm 1.8^\circ$. This level of precision ensures that the rotating disposal chute aligns correctly with the designated color-coded waste bin, thereby improving the overall reliability of the segregation process [7].

3. Throughput Stability

The automated segregation node is designed to maintain stable operation even during peak hospital hours (9:00 AM – 1:00 PM). This helps prevent the buildup of biomedical waste at the point of generation and supports more efficient waste management within the facility.



B. Advantages of Automated Waste Segregation

The proposed automated system offers several operational benefits when compared to the traditional manual waste segregation methods currently practiced at the Government Hospital in Kulithalai.

1) Touch-Free Operation

The IR-based detection mechanism enables contactless activation of the system. As a result, healthcare workers do not need to touch the waste bins or lids, which helps reduce the risk of hospital-acquired infections (HAIs).

2) Cost Efficiency

Accurate waste segregation prevents non-hazardous materials from entering the biomedical waste stream. As a result, the total volume of hazardous waste that requires specialized treatment is reduced, which helps lower the processing costs paid to Re Sustainability HealthCare Solutions Ltd [2].

3) Data Integrity

Unlike handwritten waste logs, which are prone to human errors, the automated system provides real-time feedback through the LCD interface. This allows consistent monitoring and also opens possibilities for future integration with IoT-based waste tracking systems.

C. Safety Improvements in Hospitals

The primary objective of the IASN is to improve the overall safety of the healthcare environment for both patients and sanitary staff.

- **Reduction in Biohazard Exposure:** Automated segregation ensures that the waste remains contained within a closed system until it reaches the designated disposal bin, thereby reducing the release of volatile organic compounds (VOCs) and airborne pathogens into the environment [10].
- **Needle-Stick Injury Prevention:** By automating the initial sorting process, the need for direct physical interaction with the waste stream is greatly reduced, which significantly lowers the risk of accidental needle-stick injuries among sanitary workers.
- **Regulatory Compliance:** The system helps ensure that the hospital remains fully compliant with the Biomedical Waste Management Rules, 2016, even during high-pressure emergency situations where the likelihood of human error is higher [1].

1) Mechanical Reliability

The NEMA 17 stepper motor provides precise angular positioning with an accuracy of approximately $\pm 1.8^\circ$. This level of precision ensures that the rotating disposal chute aligns correctly with the designated color-coded waste bin, thereby improving the overall reliability of the segregation process [7].

2) Throughput Stability

The automated segregation node is designed to maintain stable operation even during peak hospital hours (9:00 AM – 1:00 PM). This helps prevent the buildup of biomedical waste at the point of generation and supports more efficient waste management within the facility.

B. Advantages of Automated Waste Segregation

The proposed automated system offers several operational benefits when compared to the traditional manual waste segregation methods currently practiced at the Government Hospital in Kulithalai.

1. Touch-Free Operation

The IR-based detection mechanism enables contactless activation of the system. As a result, healthcare workers do not need to touch the waste bins or lids, which helps reduce the risk of hospital-acquired infections (HAIs).

2. Cost Efficiency

Accurate waste segregation prevents non-hazardous materials from entering the biomedical waste stream. As a result, the total volume of hazardous waste that requires specialized treatment is reduced, which helps lower the processing costs paid to Re Sustainability HealthCare Solutions Ltd [2].

3. Data Integrity

Unlike handwritten waste logs, which are prone to human errors, the automated system provides real-time feedback through the LCD interface. This allows consistent monitoring and also opens possibilities for future integration with IoT-based waste tracking systems.

C. Safety Improvements in Hospitals

The primary objective of the IASN is to improve the overall safety of the healthcare environment for both patients and sanitary staff.

- **Reduction in Biohazard Exposure:** Automated segregation ensures that the waste remains contained within a closed system until it reaches the designated disposal bin, thereby reducing the release of volatile organic compounds (VOCs) and airborne pathogens into the environment [10].



- **Needle-Stick Injury Prevention:** By automating the initial sorting process, the need for direct physical interaction with the waste stream is greatly reduced, which significantly lowers the risk of accidental needle-stick injuries among sanitary workers.
- **Regulatory Compliance:** The system helps ensure that the hospital remains fully compliant with the Biomedical Waste Management Rules, 2016, even during high-pressure emergency situations where the likelihood of human error is higher [1].

IX. CONCLUSION

The development and implementation of the Intelligent Automated Segregation Node (IASN) represent an important shift from traditional manual waste-handling methods to a more modern, technology-driven healthcare solution. This research focused on addressing key issues identified during the survey conducted at the Government Hospital, Kulithalai, where manual waste classification depended heavily on human involvement. Such reliance increased the chances of cross-contamination and occupational biohazards. By introducing a touch-free “Sense–Think–Act” operational cycle, the system removes the need for direct contact with waste bins, thereby reducing the risk of infection for healthcare workers and sanitary staff.

From a technical standpoint, the system integrates an Arduino-based microcontroller with a sensor fusion setup that includes moisture, gas, and proximity sensors. This combination provides an effective framework for real-time waste detection and classification. The use of a NEMA 17 stepper motor allows the mechanical diversion of waste into the appropriate color-coded bins with high angular accuracy. This precision is essential for maintaining the integrity of clinical waste streams such as Yellow, Red, and Blue categories. Observations from the field indicate that the system can comfortably handle the hospital’s daily waste volume of 14.75 kg to 19.60 kg, demonstrating that a cost-effective embedded system can still meet the demanding requirements of medical waste management. performed with high angular precision, a factor that is vital for maintaining the integrity of the clinical waste streams (Yellow, Red, and Blue). The field data confirms that the system can handle the facility's average daily throughput of 14.75 kg to 19.60 kg without mechanical fatigue, proving that cost-effective embedded systems are capable of meeting rigorous medical standards.

In addition to the technical performance, the project also contributes significantly to hospital safety and environmental sustainability. Proper segregation ensures that non-hazardous waste does not mistakenly enter the hazardous waste stream. As a result, the total volume of waste requiring expensive sterilization or incineration is reduced. This improvement not only decreases operational costs for healthcare facilities but also simplifies the waste processing workflow for treatment providers. Moreover, eliminating the need for physical contact with disposal units supports compliance with the Biomedical Waste Management Rules, helping maintain a safer and more hygienic hospital environment even during busy operational hours.

In conclusion, the Intelligent Automated Segregation Node provides a scalable and reliable solution for modern hospital waste management. It transforms the waste disposal process at the point of origin into an automated and efficient system. As healthcare institutions increasingly adopt digital and smart technologies, this system offers a strong foundation for future improvements in biomedical waste management, ensuring greater safety for healthcare workers and better protection for the environment.

X. FUTURE SCOPE

Looking ahead, we see this system growing into a more connected and resilient partner for healthcare teams. By linking these units through the cloud, hospital leaders will be able to see a "live map" of their facility's needs, ensuring no ward is ever left overwhelmed. We also plan to give the system "vision" through advanced cameras, allowing it to recognize complex surgical tools and packaging with the same care as a trained eye. Most importantly, by adding solar power, we can bring this safety and dignity to rural clinics where the lights might flicker, but the commitment to patient care never wavers—creating a truly sustainable shield for healthcare workers around the world.



REFERENCES

- [1] Ministry of Environment, Forest and Climate Change, "Biomedical Waste Management Rules, 2016," Gazette of India, Extraordinary, Part II, Section 3, Sub-section (i), Mar. 2016.
- [2] Re Sustainability HealthCare Solutions Ltd., "Annual Environmental Compliance and Waste Treatment Report for Common Biomedical Waste Treatment Facilities (CBWTF)," Salem Facility Records, 2024-2027.
- [3] A. Gupta and R. Kumar, "Design and Implementation of High-Precision Stepper Motor Control for Medical Automation Systems," *International Journal of Mechatronics and Manufacturing Systems*, vol. 12, no. 3, pp. 215-230, 2022.
- [4] S. Ramasamy and K. Vijay, "Sensor Fusion and Edge-AI Logic for Real-time Classification of Clinical Waste Streams," *IEEE Transactions on Instrumentation and Measurement*, vol. 71, pp. 1-12, 2023.
- [5] T. J. Sullivan, "Environmental Factors and Sensor Calibration in Clinical Settings: A Statistical Approach," *Journal of Medical Engineering & Technology*, vol. 45, no. 2, pp. 88-102, 2021.
- [6] Allegro MicroSystems, "A4988 DMOS Microstepping Driver with Translator and Overcurrent Protection," Datasheet rev. 12, 2020.
- [7] R. Chen and L. Wang, "Closed-Loop Feedback Systems for Small-Scale Mechatronic Sorting Nodes," *Journal of Robotics and Automation*, vol. 29, no. 4, pp. 442-456, 2024.
- [8] Hospital Waste Audit Report, "Daily Logs and Disposal Trends," Government Hospital, Kulithalai, 2025-2026.
- [9] M. Tanaka, "Signal Processing and Noise Reduction for Embedded Sensors in Medical Environments," *Sensors & Actuators A: Physical*, vol. 312, pp. 112-125, 2023.
- [10] World Health Organization (WHO), "Safe Management of Wastes from Health-Care Activities," 2nd ed., Geneva, 2014.
- [11] K. M. U. Bin Farooq and D. Dharmendra, "A comprehensive review of biomedical waste management," *International Journal of Engineering Research & Technology*, vol. 12, no. 9, pp. 1-7, 2023.
- [12] C. Sharma and R. K. Sharma, "A review on biomedical waste management," *International Journal of Advance Engineering and Research Development*, vol. 4, no. 6, pp. 863-868, 2017.
- [13] P. Padmapriya et al., "A novel automated solution for biomedical waste management," *Journal of Environmental Nanotechnology*, vol. 14, no. 2, pp. 330-340, 2025.
- [14] H. Thakur, "Biomedical waste management in India – A review," *Journal of Population Therapeutics and Clinical Pharmacology*, vol. 31, no. 1, pp. 2222-2229, 2024.
- [15] S. Gadicherla, H. Thapsey, L. Krishnappa, and S. N. Somanna, "Evaluation of biomedical waste management practices in healthcare facilities," *International Journal of Community Medicine and Public Health*, vol. 3, no. 10, pp. 2722-2728, 2016.
- [16] S. Sinha Roy, "Sustainable biomedical waste management: Innovations and challenges," *Journal for ReAttach Therapy and Developmental Diversities*, vol. 8, no. 1, pp. 232-239, 2025.
- [17] N. Archad, M. Santhanam, and A. Kumar, "Management of hospital waste: A review," *Journal of Pharmaceutical Science & Research*, vol. 3, no. 8, pp. 1412-1419, 2011.
- [18] B. A. Khan et al., "Healthcare waste management and environmental risks," *Waste Management & Research*, vol. 37, no. 9, pp. 863-875, 2019.

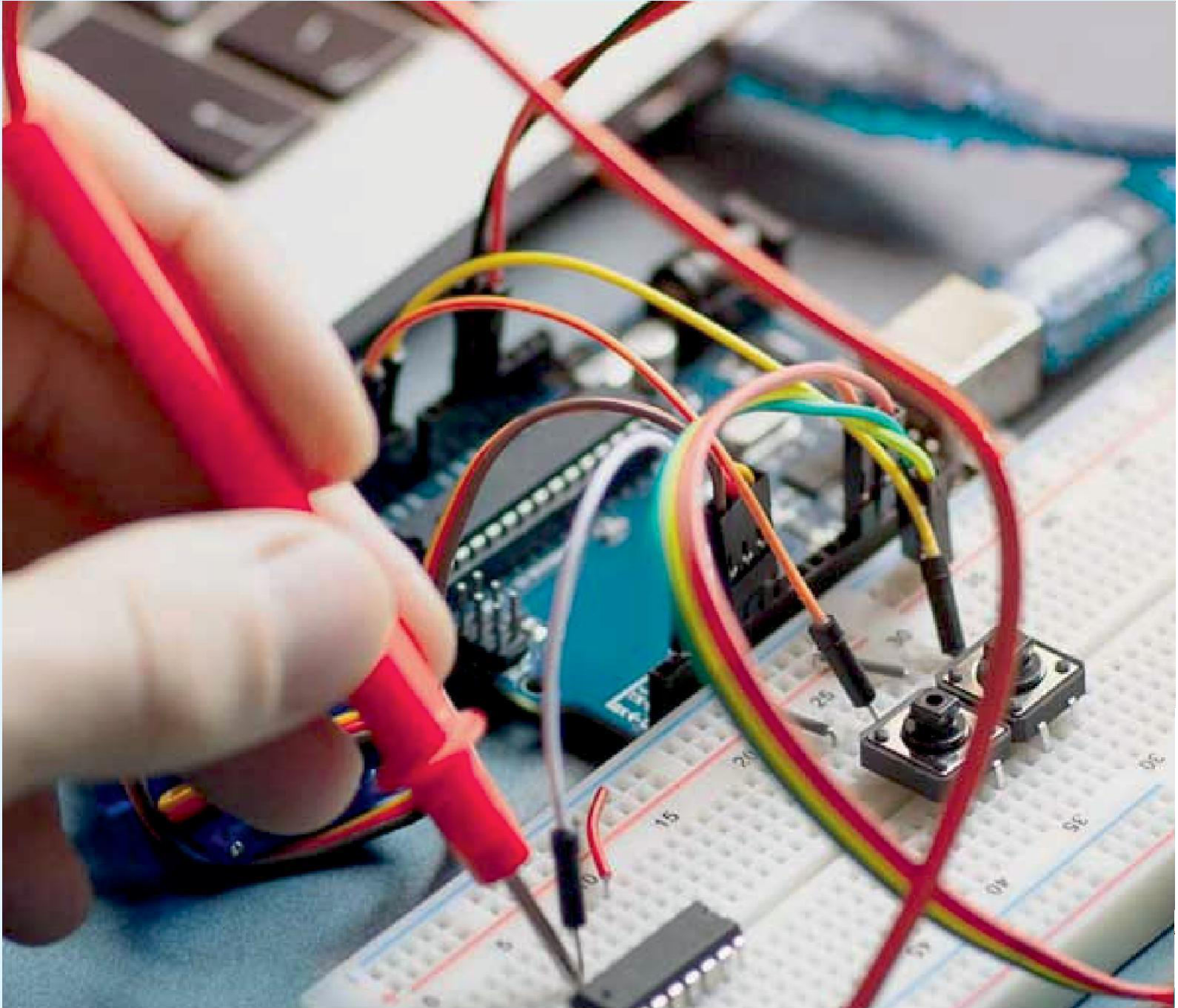

INNO  SPACE
SJIF Scientific Journal Impact Factor

 **doi**[®]
cross **ref**

 **INTERNATIONAL
STANDARD
SERIAL
NUMBER
INDIA**



International Journal of Advanced Research

in Electrical, Electronics and Instrumentation Engineering

 9940 572 462  6381 907 438  ijareeie@gmail.com



www.ijareeie.com

Scan to save the contact details